

# ARTERIO RS

## AIKMAN END TABLE

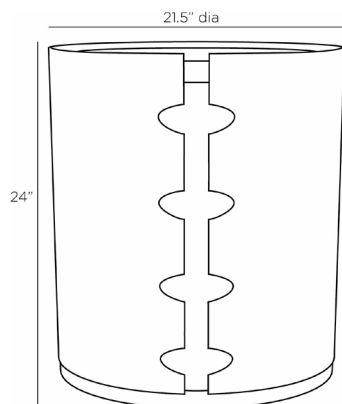

FE117

H: 24 IN, Dia: 21.50 IN

Antique Brass

Contract Recommendations: Adding a lacquer coating provides additional protection

An antique brass finished iron band encircles a waxed ebony mango wood top on this elegant end table. Inspired by a chunky cuff bracelet, the table is hollow for ease of movement.

### APPEARANCE

Material	Iron, Wood
Material Type	Mango
Finish	Antique Brass
Top Coat/Sealant	true

### SHIPPING

Shipping Requirements	TruckShip
Product Weight	64 LBS
Gross Weight 1	73.87 LBS
Shipping Box 1	H: 25.6 IN, L: 23.2 IN, W: 23.2 IN

### ADDITIONAL INFO

Table Tilt Test Results	Passes 15 Degrees
-------------------------	-------------------

### CONTRACT

Contract Suitable	Adding a lacquer coating provides additional protection
-------------------	---