

ARTERIOS

BRINKLEY MIRROR

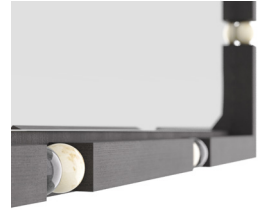
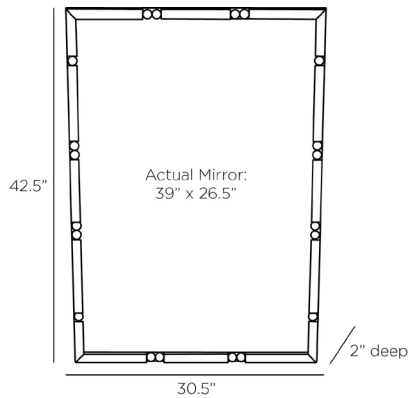

WM126

H: 42.5 IN, W: 30.5 IN, D: 2 IN

Ebony, Mango Wood

Contract Suitable As Is

A rectangular frame of ebony finished mango wood is punctuated with marble balls in contrasting hues. These black and white details float about the perimeter, adding a geometric playfulness to the simple form. This versatile accent can be hung both vertically and horizontally. Fitted with security cleat hardware. Finish will vary.

APPEARANCE

Material	Mango Wood, Marble, Mirror
Finish	Black, Plain, White
Finish Will Vary	true
Top Coat/Sealant	true

DIMENSIONS

Mirror Size	0.5 H: 39 IN, W: 26.5 IN
-------------	-----------------------------

SHIPPING

Shipping Requirements	TruckShip
Product Weight	43.3 LBS
Gross Weight 1	53 LBS
Shipping Box 1	H: 40 IN, L: 47 IN, W: 8 IN

ADDITIONAL INFO

Features	T-Screw Hardware Included
Hanger Position	Vertical & Horizontal
Hanger Type	Security Cleat
Hanger Size	18"

CONTRACT

Contract Suitable	true
-------------------	------